

# Installation Overview

# TriStar Series

---

Revised 08/11

Congratulations on the purchase of your Stewart sign. This document is intended to give a general overview of our installation process. Detailed information for your specific sign is provided in your Owner's Manual.

## Table of Contents

- **Preparing the Site ..... 2-3**
- **Sign Delivery & Uncrating..... 4**
- **Sign Assembly ..... 5-6**

*www.stewartsigns.com*

1-800-237-3928 Fax 941-378-2765  
2201 Cantu Court, Suite 215, Sarasota, Florida 34232

**Stewart**  
AMERICA'S PREMIER SIGN COMPANY

# Preparing the Site

(Done in advance of sign arrival)

1

Assemble the tools/components needed.

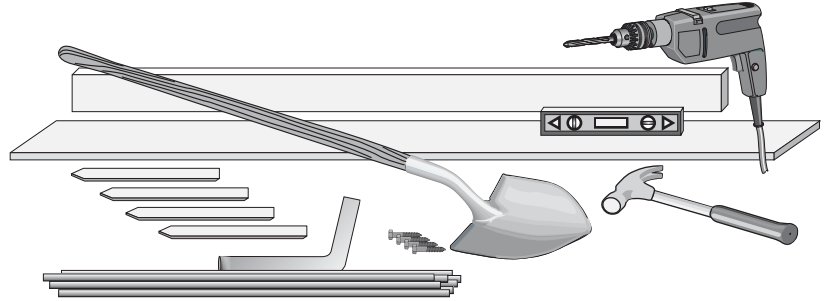

2

Dig and form hole.  
*Footer Detail provided with Owners Manual*

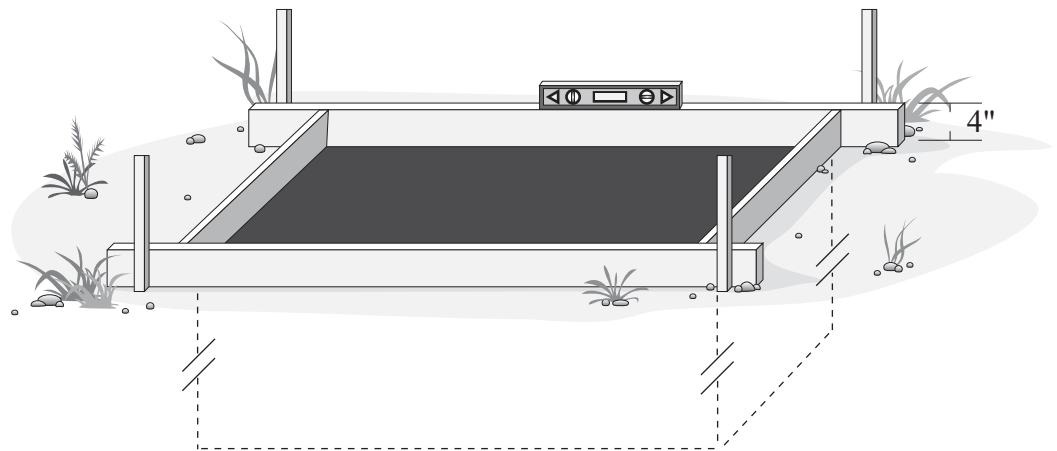

3

Position anchor bolts on wood as shown on template in Owner's Manual.

Attach rebar with wire ties.

Note: On single sided signs, facing sign, electric is in right leg.

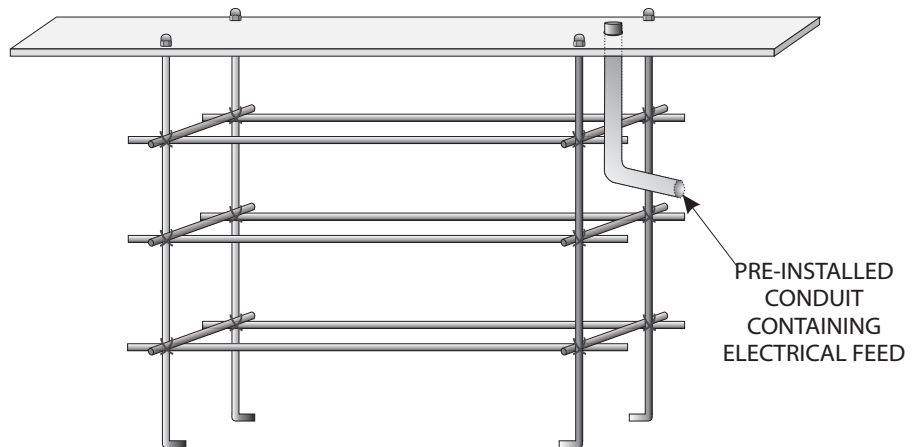

# Preparing the Site

4

Center anchor bolt/rebar assembly in hole and secure to form. Then pour concrete.

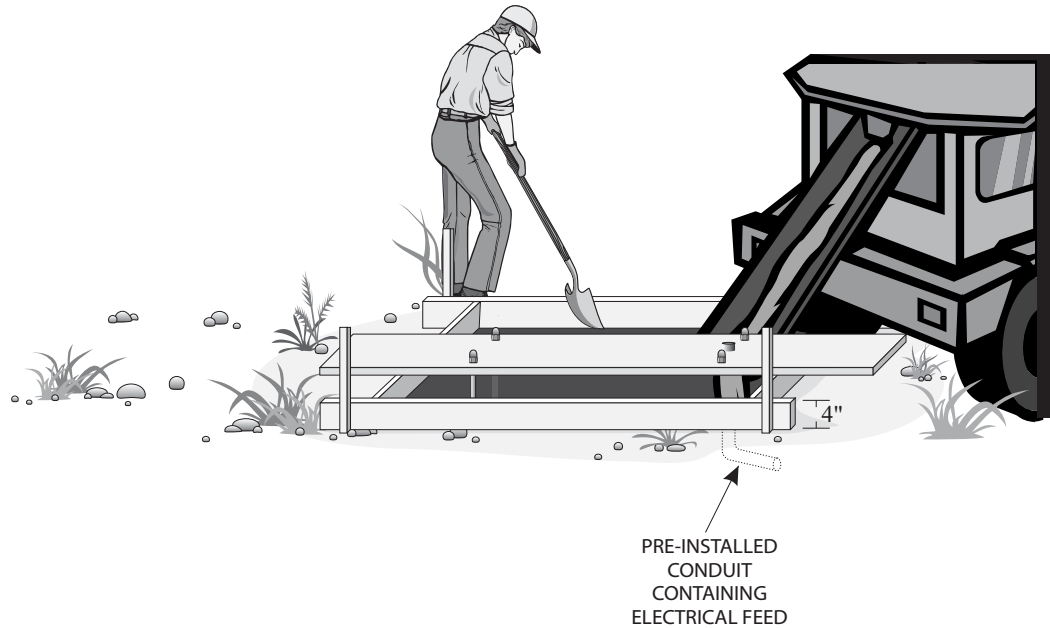

5

Finished site. Pad should extend 4" above grade.

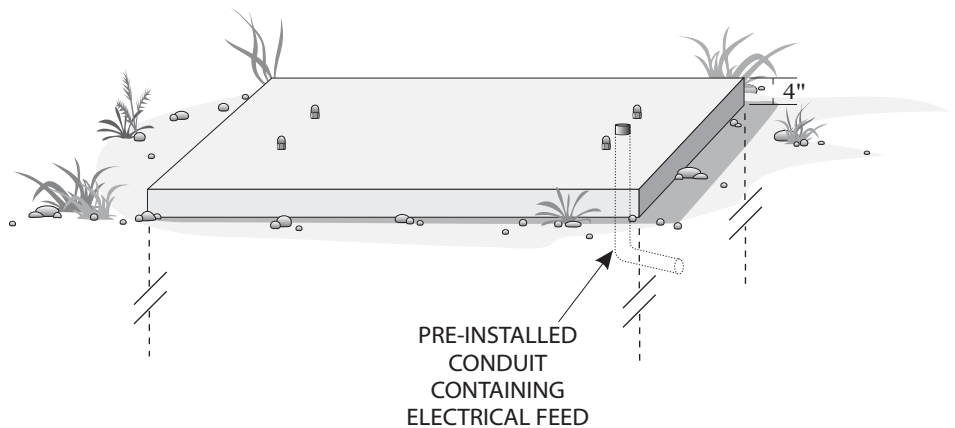

# Delivery of Sign

1

The sign arrives in one or more crates.  
All signs under 8'6" tall arrive fully assembled in one crate.

2

You will need sufficient manpower or lifting equipment to offload your sign.

Refuse delivery of damaged signs.



# Uncrating Sign

1

Uncrate and inspect all components immediately upon receipt.

2

Locate and remove touch-up paint from crate located in cardboard box, as shown in illustration.

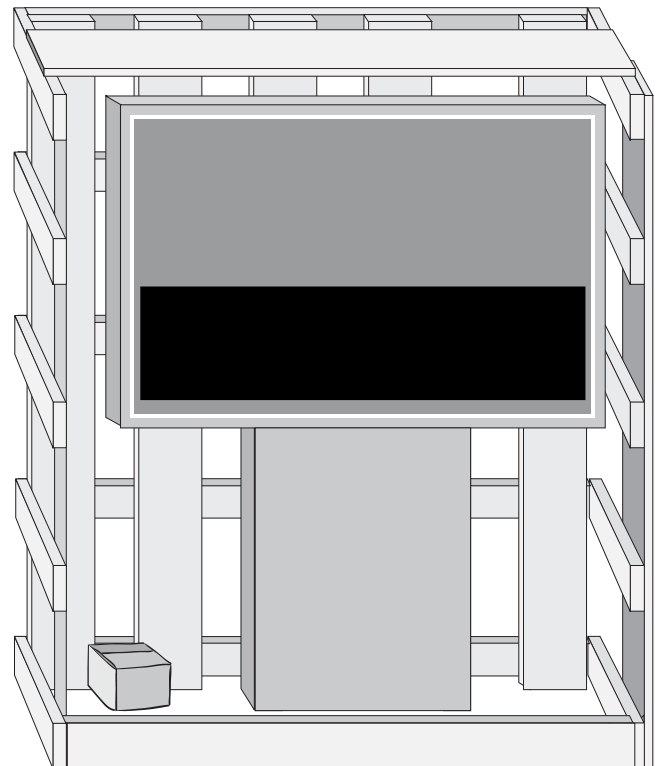

# Sign Assembly

\*Signs with an overall height under 8'6" arrive as a single component skip steps 1-5

1

Lay the legs near the upper cabinet stub legs on smooth, level, protected ground.

**Do not remove the face(s) of the TriStar.**

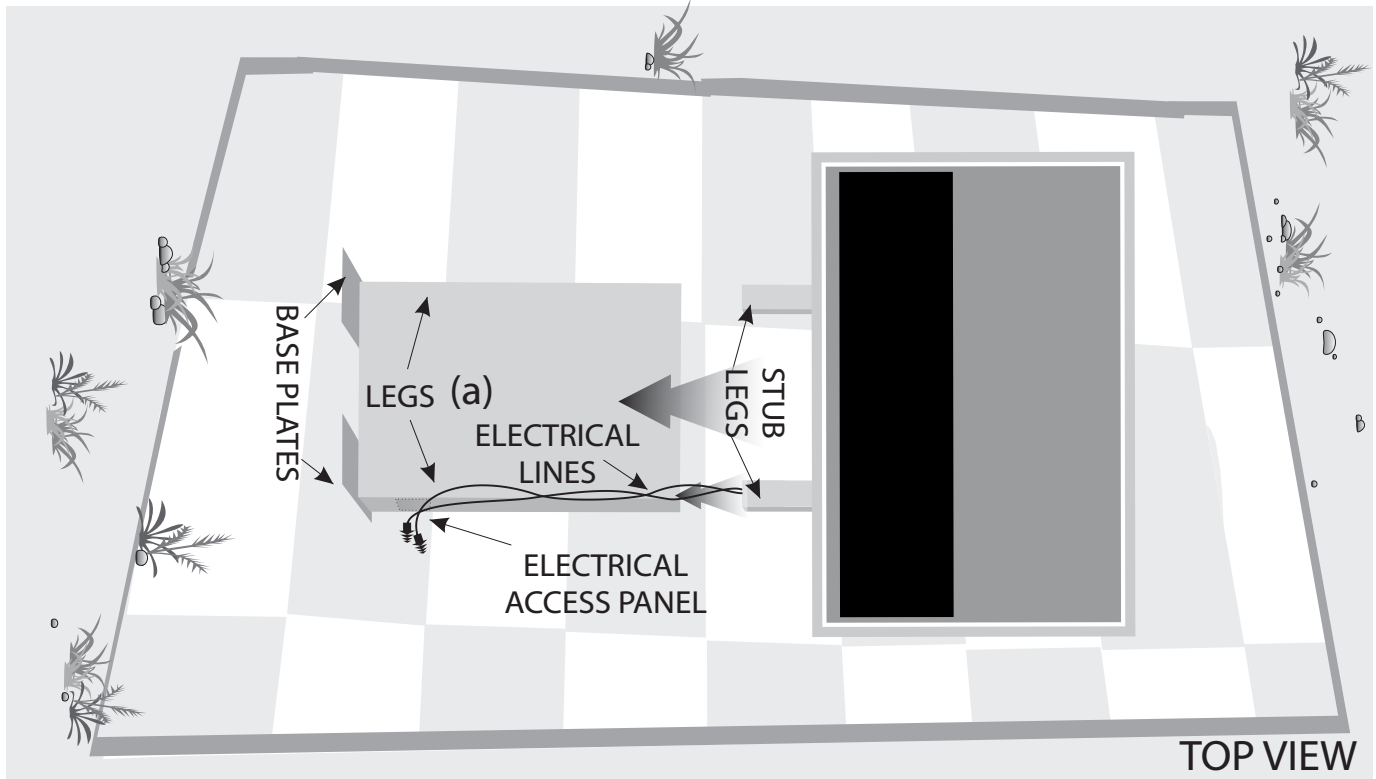

2

Pull the electrical lines out of the stub legs and feed electrical down the leg that has the electrical access panel.

4

Slide legs or support structure on to stub legs, being careful not to pinch electrical wires.

3

Remove the bolts from the stub legs.

5

Fasten the support structure to the stub legs of the sign with bolts.

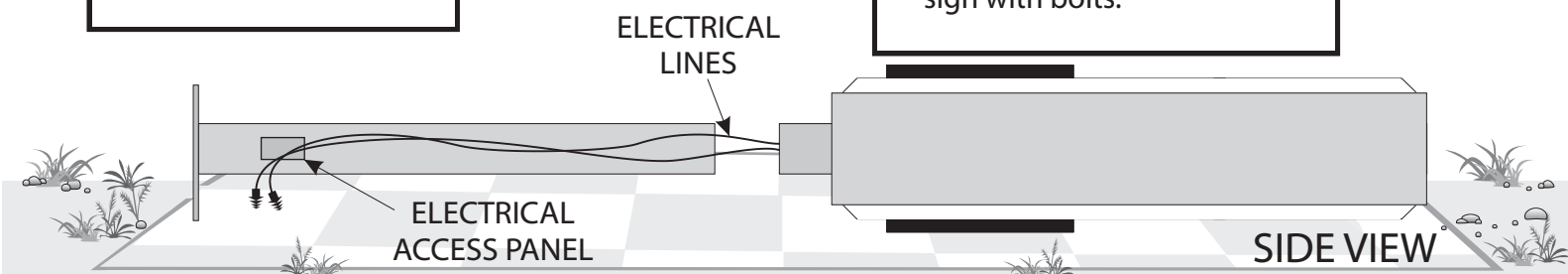

# Sign Assembly

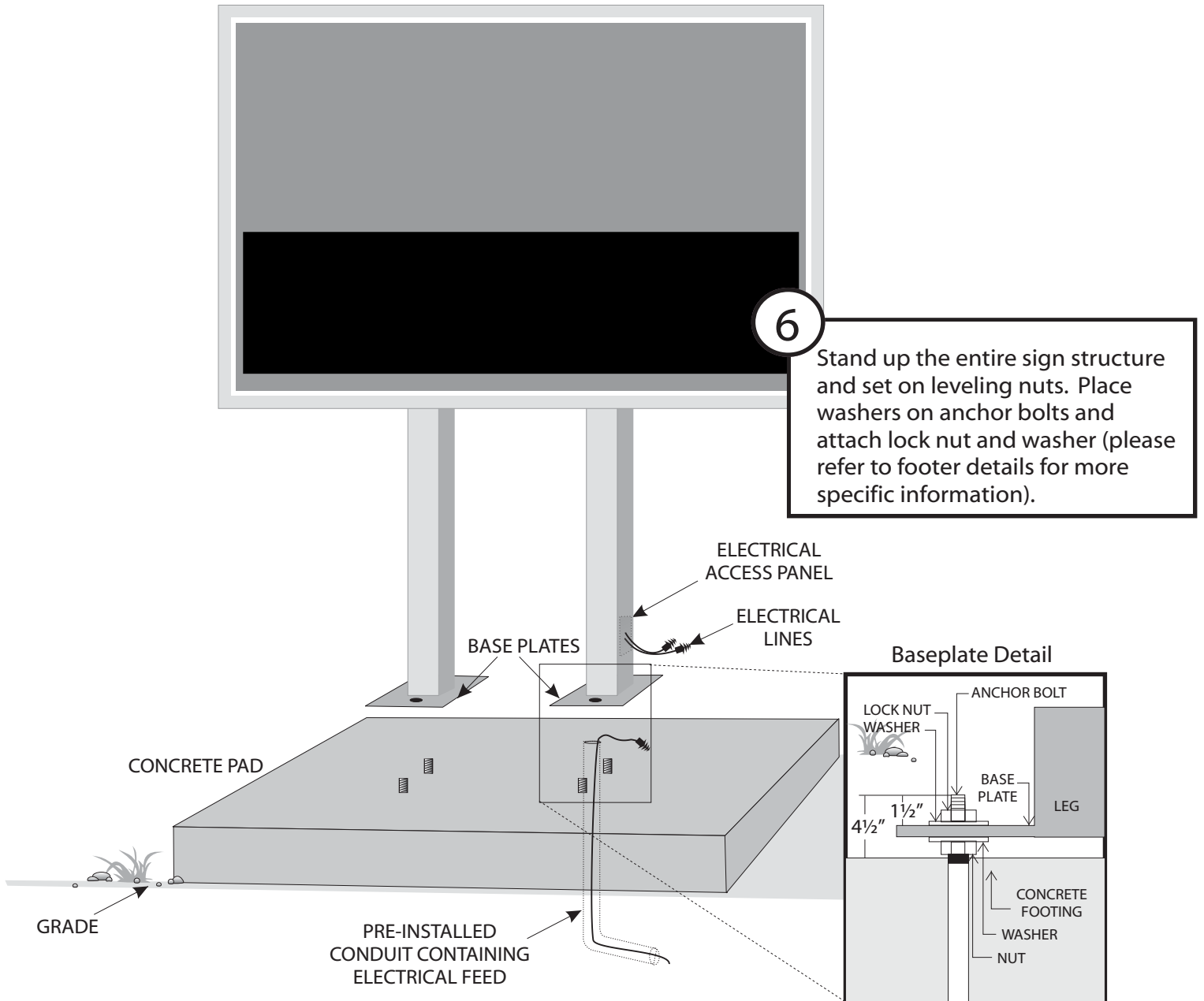

**7** After installation is completed, use touch up paint provided for coating small scratches on metal areas only.

Thank you for purchasing a Stewart sign. We hope you are pleased with the quality of our work and the high level of service our company has offered you. If you have any questions, please contact us at 800-237-3928.