



Dear Stewart Signs Customer:

Thank you for buying a Stewart sign! This Owner's Manual is provided to guide you through the process of receiving, installing and operating your new sign. Please feel free to print it out in order to have it available for easy reference.

Read the manual carefully as there are important steps to be taken to assure maximum satisfaction with the delivery, installation and operation of your new sign and also to assure that the warranty will not be invalidated.

Care has been taken to provide a quality product that will serve you well for many years. If you are pleased with your new sign, please tell someone who also may have an interest in new signage. You can earn **\$100** for each referral you give which results in a sale to an organization that we are not already doing business with by filling out the referral form on our website: www.stewartsigns.com/referral.

If you have access to the Internet, you will find answers to the most commonly asked questions at www.stewartsigns.com/support/ 24 hours a day 7 days a week.

Welcome to the family of the thousands of satisfied Stewart sign owners. Remember to keep this Owner's Manual in an easily accessible place for all who will be responsible for your sign. If for any reason you are not entirely satisfied with your new sign, please contact our Customer Support Department at 1-800-237-3928.

Sincerely,
The Stewart Signs Staff

PLEASE READ CAREFULLY BEFORE SIGN IS DELIVERED



TABLE OF CONTENTS

SHIPPING AND FREIGHT CLAIMS.....	3
Shipping Your Sign	3
Transfer of Ownership	3
International Shipments.....	3
Sign Delivery Details and What to Do in the Event of Shipping Damage	4
Reporting Freight Damage	4
PRE-INSTALLATION	5
Preparing the Site.....	5
Uncrating Your Sign.....	8
Sign Assembly.....	9
MAINTENANCE	11
Cleaning and Maintenance for the Sign Face and Vandal Cover	11
Cleaning and Maintenance for the Cabinet and Frame	12
Changing Lamps and Removing Sign Faces.....	13
Replacing a Ballast	14
Troubleshooting	15
SUPPLY ORDERS	16
Ordering Changeable Copy Letters, and Other Sign Supplies.....	16
WARRANTY	17
Lifetime Warranty	17
Publicize Your New Sign!	20

SHIPPING AND FREIGHT CLAIMS

Shipping Your Sign

Your new Stewart sign will be shipped by common carrier. Great care is taken to ensure that each sign is properly crated to protect against shipping hazards. All Stewart sign products are shipped with an authorized transportation company in good undamaged condition. The products are packaged in approved containers or crates. Your signature is verification that you received the goods we shipped in the same good condition.

Transfer of Ownership

- **By law, ownership of the sign transfers from us to you when the sign is picked up by the trucking company at the place of shipping.**
 - If it is damaged in transit, it is the responsibility of the trucking company to have it repaired or replaced at the trucking company's expense.
- **The damage must be noted on the bill of lading.**
 - Failure to do so will result in refusal of your claim and non-payment for damage or loss.
- **You must uncrate your sign immediately upon delivery.**
 - If you do not uncrate your sign and at a later date you discover concealed damage, it will result in the refusal of your claim and non-payment for damage or loss.

International Shipments

In addition to the above requirements and information, your sign will arrive with any ancillary items (i.e. anchor bolts, washers, etc.) that were ordered, in or attached to the crate. This reduces your shipping cost and the chance of lost merchandise.

The packing slip will list all of the items included in the shipment and you will need to verify the inclusion and condition of each item before accepting delivery of your shipment.

Sign Delivery Details and What to Do in the Event of Shipping Damage

Your new sign will be shipped by common carrier. Your signature on the delivery slip is verification that you received the goods in good condition.

IF SHIPMENT IS DAMAGED, IMMEDIATELY CONTACT STEWART SIGNS AT 1-800-237-3928

Reporting Freight Damage

Do not sign the Delivery Receipt until you inspect the shipment for damage. The driver must wait until you sign the Delivery Receipt. Carefully inspect for obvious and/or concealed damage. If Stewart Signs cannot be reached, **refuse the damaged merchandise. Failure to note damage on the Delivery Receipt will result in the freight carrier's denial of your claim.**

1. **OBVIOUS DAMAGE:** All containers should be carefully inspected for visible and obvious damage. If any damage or shortage is discovered, the driver must indicate such on all copies of the delivery receipt and sign the statement. **In the event of damage, you should refuse the damaged merchandise and contact Stewart Signs.** Under no circumstances should you accept the delivery when damage is observed. Accepting delivery will only complicate processing and delay settlement.
2. **CONCEALED DAMAGE:** Indications of possible concealed damage inside containers may be: breaks, dents, tears, creases and holes in the protective wrap surrounding the sign crate or loose strapping. Call Stewart Signs Customer Support at 1-800-237-3928. **For complete coverage of any concealed damage, it must be discovered and reported on the day of delivery. If it is discovered and reported within 10 days of delivery, the coverage is reduced to 30%-50% of the claim and if it is discovered more than 10 days later, it will result in total refusal of the claim.**
3. **MINOR DAMAGES:** In case of scratches on the cabinet, touch-up paint is included in the crate. Do not attempt to paint the polycarbonate faces.
4. **UNLOADING YOUR SIGN:** Many freight companies will load a truck and send the driver alone to make deliveries. It is your responsibility to off-load your shipment. Upon notification of delivery, please arrange to have the appropriate amount of help available to assist in the unloading process. **Stewart Signs always recommends lifting equipment. Always think safety first.**

The following items are **NOT** part of the normal shipping charges. If required, additional costs will be incurred.

- Lift gates
- Changing a delivery address after the truck has left the factory
- Leaving the sign at the freight terminal waiting for delivery

PRE-INSTALLATION

Preparing the Site

1

Assemble the tools/components needed.

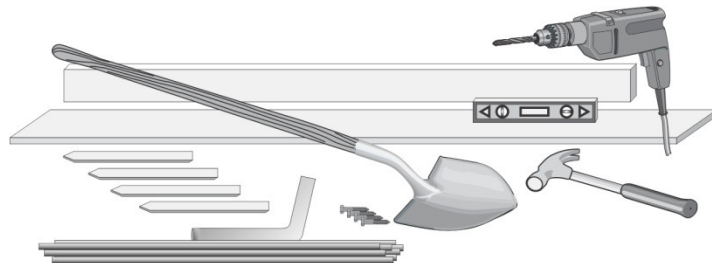

2

Dig and form hole.
Footer Detail provided with Owners Manual

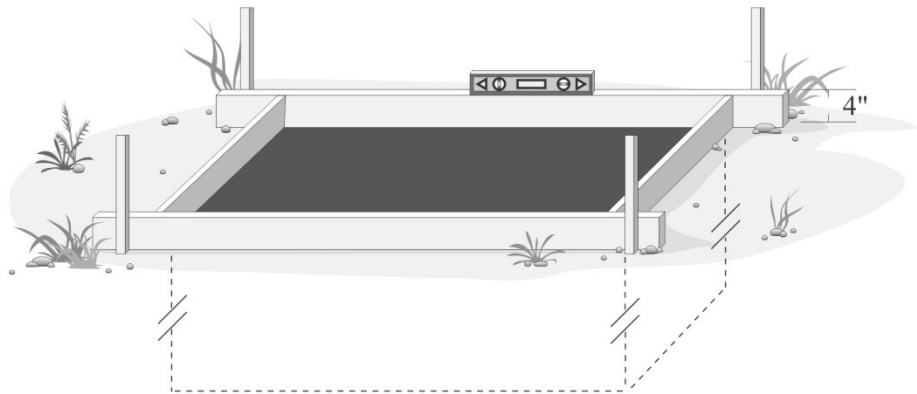

3

Position anchor bolts on wood as shown on template in Owner's Manual.

Attach rebar with wire ties.

Note: On single sided signs, facing sign, electric is in right leg.

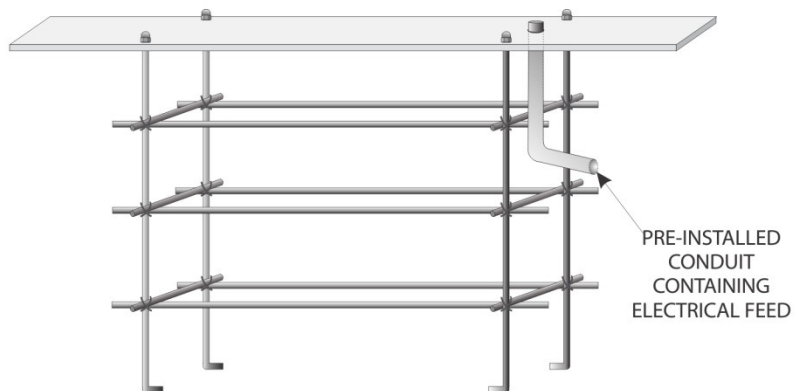

4

Center anchor bolt/rebar assembly in hole and secure to form. Then pour concrete.

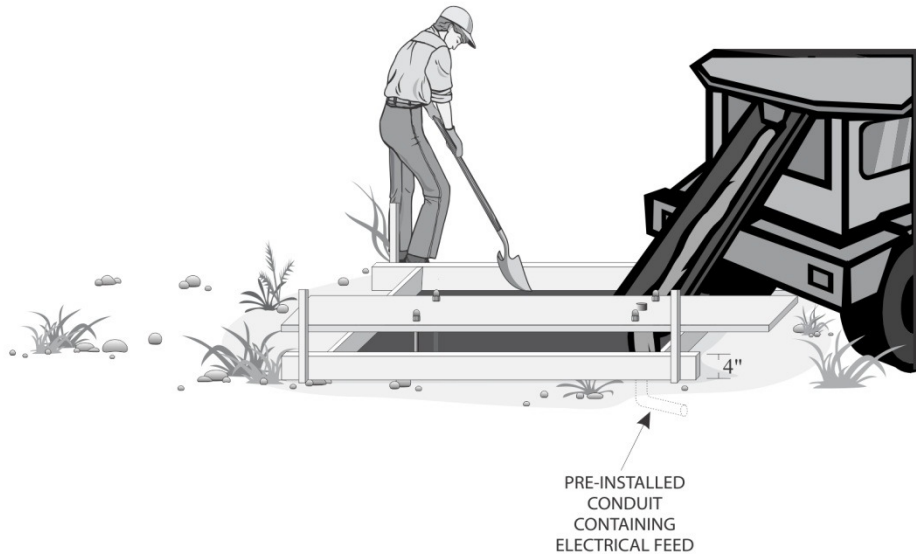

5

Finished site. Pad should extend 4" above grade.

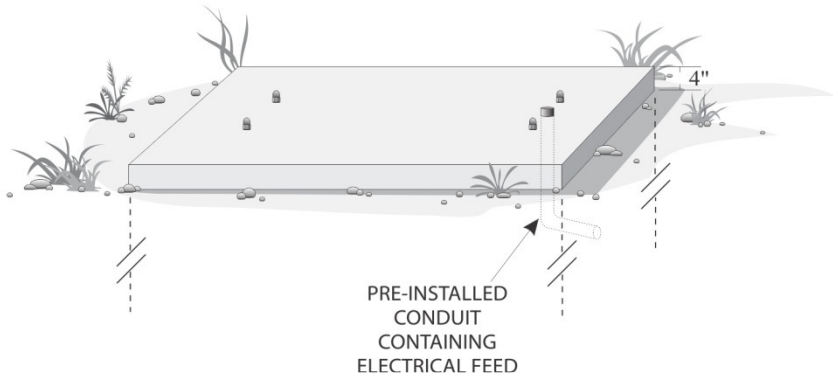

Offloading a Sign from the Delivery Truck

The following is one option you can use when offloading your sign from the delivery truck. If you feel more comfortable with another method, please utilize the option that best fits your unique situation.*

Be sure you know how much your sign weighs before organizing help for the delivery. Your sign consultant can give you the approximate weight of the crated sign weeks before it ships. As a general rule you should have one able person for every one hundred pounds. You will typically need a minimum of four people to offload the sign.

STEP 1



STEP 2



STEP 3



When offloading the sign, it is generally easiest when the sign is brought to the edge of the truck, tilted, and slid down as illustrated above. This typically results in never having to lift the entire weight.

If your sign weighs 600 pounds or more or you are not 100% confident that you have enough manpower, **we recommend lifting equipment**. ALWAYS THINK SAFETY FIRST.

In addition, if the delivery truck cannot park near the installation site, removing the crate reduces the weight by 100-150 pounds.

**Please note that this document is meant as a guideline and the delivery process is the full responsibility of the customer. J.M. Stewart Corporation and its employees are to be held harmless from the individual decisions and actions involved in the process.*

Uncrating Your Sign

1

Uncrate and inspect all components immediately upon receipt.

2

Locate and remove touch-up paint from crate located in cardboard box, as shown in illustration.

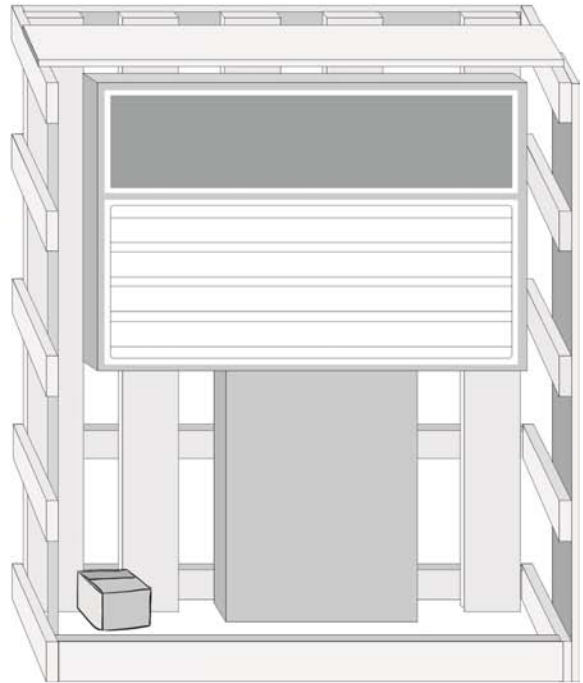

Sign Assembly

**Signs with an overall height under 8'6" arrive as a single component in which case steps 1-5 can be skipped.*

- 1 Lay the legs near the upper cabinet stub legs on smooth, level, protected ground.

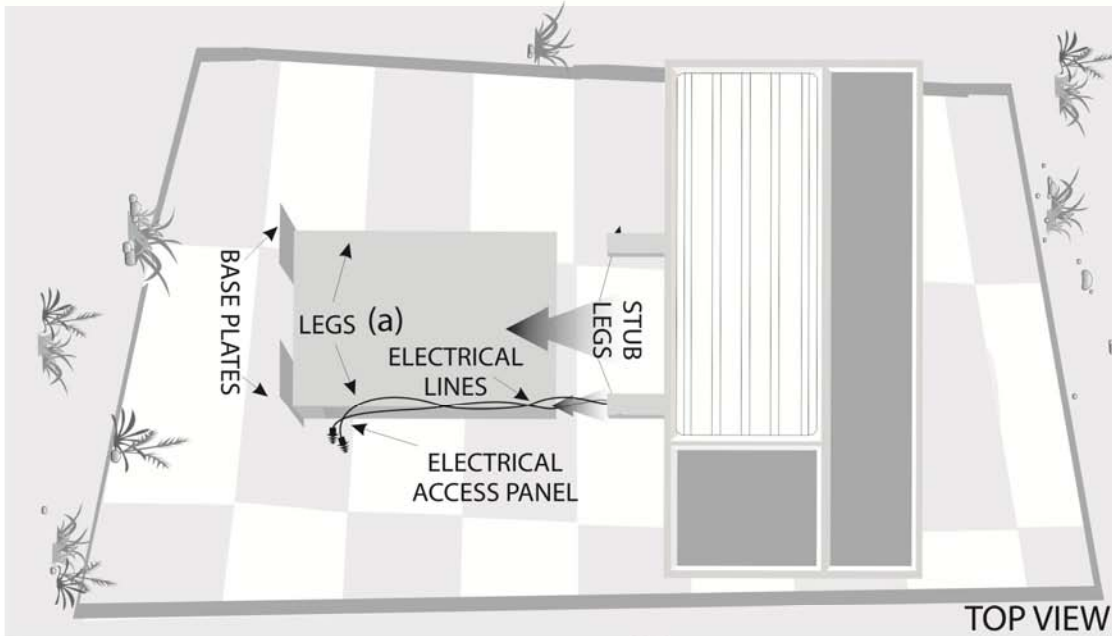

- 2 Pull the electrical lines out of the stub legs and feed electrical down the leg that has the electrical access panel.

- 4 Slide legs or support structure on to stub legs, being careful not to pinch electrical wires.

- 3 Remove the bolts from the stub legs.

- 5 Fasten the support structure to the stub legs of the sign with bolts.

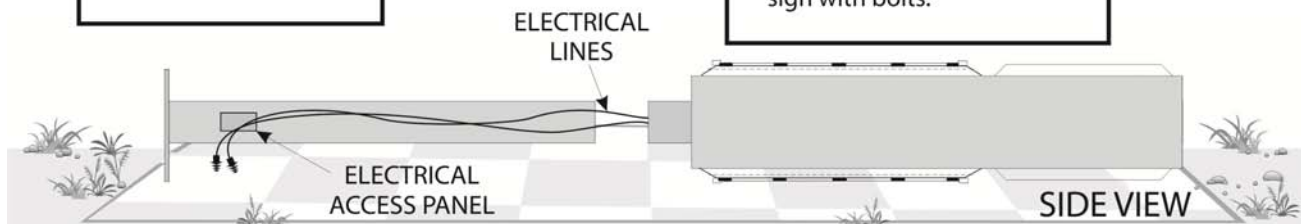

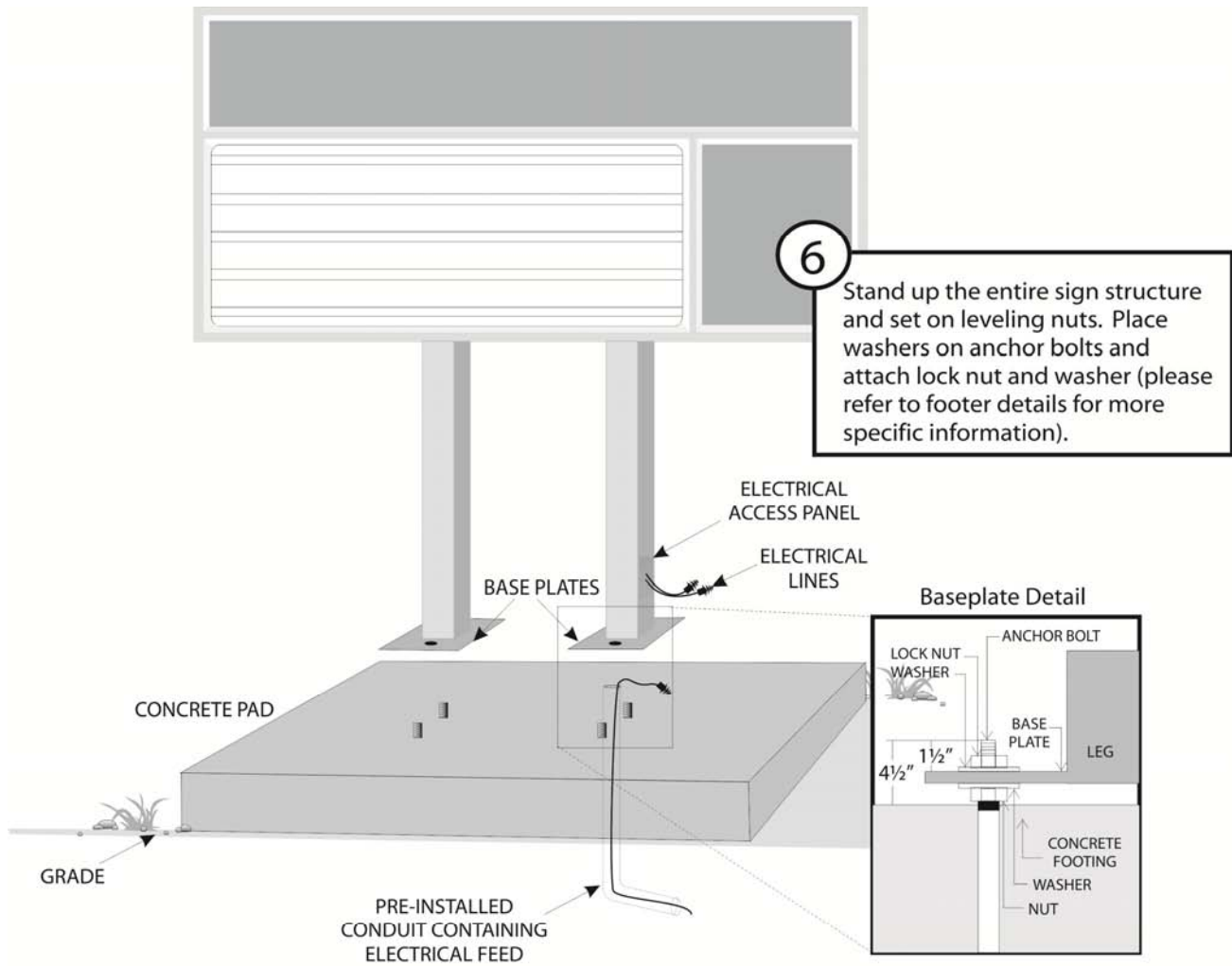

7 After installation is completed, use touch up paint provided for coating small scratches on metal areas only.

MAINTENANCE

Cleaning and Maintenance for the Sign Face and Vandal Cover

MAKROLON® SL

The proprietary UV-resistant surface on MAKROLON® SL sheet significantly improves long-term weatherability. Clean periodically with proper procedures and compatible cleaners to prolong service life.

For general cleaning, it is recommended that the following instructions and cleaning agents be used.

CLEANING PROCEDURES

1. Rinse sheet with lukewarm water.
2. Wash sheet with mild soap and lukewarm water.
3. Use a soft cloth or sponge and gently wash to loosen remaining dirt and grime. DO NOT SCRUB or use paper towels, brushes, or squeegees; the surface treatment on MAKROLON® SL sheet is not mar-resistant.
4. Repeat rinse and dry with a soft cloth to prevent water spotting.

COMPATIBLE CLEANING AGENTS

FORMULA 409®
JOY®
PALMOLIVE LIQUID®
TOP JOB®

BLEACH (mix 1-cup bleach to 1 gallon water to clean tracking using a soft paint brush. To get underneath tracking, rinse with a garden hose or a bucket of clean water)

*DO NOT USE BUTYL CELLOSOLVE, LYSOL® OR PINE-SOL® ON THE TREATED SURFACE.

GRAFFITI REMOVAL

DRIED EGG, SPRAY PAINT, PERMANENT MARKER

1. VM&P grade Naphtha (available at better hardware stores- this brand must be used)
2. Isopropyl Alcohol
3. Freon T.F.
4. Lacryl Thinner (this product can be ordered through Stewart Signs)

Cleaning and Maintenance for the Cabinet and Frame

Powder coat paint offers superior color and gloss retention along with graffiti, chip, and impact resistance.

CLEANING PROCEDURES

1. Rinse with water.
2. Wash with mild soap & water
3. Use a soft cloth or sponge (DO NOT SCRUB)
4. Repeat rinse & dry with a soft cloth to prevent water spotting

LIME DEPOSIT REMOVAL

1. A solution of 10 parts water to 1 part vinegar or
2. A solution of 1 part water to 1 part baking soda or
3. A basic rubbing compound

WAXING YOUR SIGN

ONCE A YEAR IS RECOMMENDED

1. Johnson Paste Wax[®]
2. Turtle Wax[®]
3. Meguiar's[®] Glaze

GRAFFITI REMOVAL

DRIED EGG, SPRAY PAINT, PERMANENT MARKER

1. 3M[™] Bug & Tar (available at hardware stores)
2. WD-40[®]
3. Isopropyl Alcohol

Changing Lamps and Removing Sign Faces

Stewart signs have been designed to be as close to maintenance-free as any sign can be. However, you may occasionally need to change one of the energy efficient fluorescent lamps. Here is all you have to do:

1. Remove the aluminum retainer (molding) on one end of the sign. These are fastened to the sign frame by aluminum screws.
2. Some sign faces are also held in place by screws through the sign face flange. Retainers and screws must then be removed from each end.
3. Slide out the entire sign face. This will reveal the fluorescent lamps.
4. Remove any electrical tape securing the lamps in the sockets for shipping purposes. There is no need to re-tape new lamps. Remove the lamps by firmly grasping the tube with both hands and gently pushing toward the end which has the spring loaded socket; or "roll out" non-spring-loaded sockets.
5. Replace the burned out lamp with an equivalent high output lamp. The necessary information is found on one end of each lamp. If this is no longer legible, call J.M. Stewart Corporation at 800-237-3928 and we will furnish you with the information you need.
6. Replace both the face and the retainer along with any screws that may be in the face.

HELPFUL HINTS

If you feel the sign is too bright when illuminated, you may find the following technique helpful. Using black electrical tape, wrap each lamp in a very loose "barber pole" fashion.

Remember this is only to reduce the lamp output and too much tape will darken the sign.

It is recommended that you never turn your sign off:

- The small amount of heat generated by the large lamps and ballasts will reduce or eliminate harmful condensation.
- Lamps and ballasts will last longer.
- The person who needs to read your message may be the person who will likely drive by during the very late or very early hours.
- The cost of the electricity is so nominal that it will likely be less than lamp and ballast replacement.

Replacing a Ballast

The ballast controls the power flow to the fluorescent lamps. Depending upon the model of sign, one or more ballasts are required for each sign.

If your sign fails to illuminate, or if sections of the sign involving more than one lamp are dark, follow these simple steps:

1. If the entire sign fails to light, check the power source to the sign and electrical connections.
2. If individual lamps fail, use the procedure for replacing lamps located in on page E-3 and make sure that all lamps are firmly seated in their sockets.
3. Record the model numbers of all ballasts within the sign.

If your ballast is under warranty please contact customer support at 1-800-237-3928 with the model number for further instructions.

Troubleshooting

PROBLEM	POSSIBLE CAUSE	SOLUTION
<i>A lamp is out.</i>	<ul style="list-style-type: none"> • <i>Lamp burnt out.</i> • <i>Loose lamp.</i> • <i>Bad connection</i> 	<ul style="list-style-type: none"> • <i>Change lamps.</i> • <i>Tighten lamps in socket.</i> • <i>Check connections.</i>
<i>Several lamps are out.</i>	<ul style="list-style-type: none"> • <i>Lamp burnt out.</i> • <i>Loose lamp.</i> • <i>Bad ballast.</i> 	<ul style="list-style-type: none"> • <i>Change lamps</i> • <i>Tighten lamps in sockets.</i> • <i>Test ballast.</i>
<i>Sign is out.</i>	<ul style="list-style-type: none"> • <i>Individual lamp burnt out.</i> • <i>Power off.</i> • <i>Bad electrical connection to sign.</i> • <i>Bad ballast.</i> 	<ul style="list-style-type: none"> • <i>Check each lamp.</i> • <i>Turn power on.</i> • <i>Check wiring.</i> • <i>Test ballast.</i> • <i>Call J.M. Stewart Customer Support department.</i>

***Note:** On single ballast signs only, one bad lamp may cause the whole sign to be out.

It is the responsibility of the customer to consult with or hire a licensed, professional electrical contractor to electrically connect the sign.

The J.M. Stewart Corporation, under no circumstances or in any way, covers the cost of electrical problems due to faulty power source.

SUPPLY ORDERS

Ordering Changeable Copy Letters, and Other Sign Supplies

Please visit our website at
http://www.stewartsigns.com/support/support_parts.php

WARRANTY

Lifetime Warranty

The J.M. Stewart Corporation (Stewart Signs) warrants your new sign as follows, subject to the conditions herein provided:

Sign Structure and Sign: Under normal use and service should the sign structure or identification/changeable copy sign malfunction during the life of the sign due to defects in workmanship or materials, Stewart Signs will at its option repair or replace any of the defective materials, (with the exception of lamps and ballasts). Faulty ballasts will be exchanged for new ballasts for a period of three years.

Vandalism to Sign Faces and Vandal Covers: This Lifetime Warranty also covers polycarbonate faces and vandal covers against breakage due to vandalism for the life of the sign. Warranty protection does not extend to these surfaces if damaged by gunshots, or when damaged coincident with the damage to the sign cabinet or vandal cover frame.

Additional Warranty Terms: This warranty covers normal use and service. Damage caused by abuse, lightning and other acts of God, and any consequential or contingent liability is excluded from this warranty. Warranty claims must be registered with Stewart Signs within thirty (30) days of damage or malfunction. Stewart Signs reserves the right to visit the site of the installation or to require documentation of the claim before assuming any responsibility under the provisions of this warranty. Removing and reinstalling repaired or replacement parts is the responsibility of the owner.

Upon delivery, incidental blemishes and scratches are considered normal unless they can be viewed 20 feet or more under normal use conditions. Stewart Signs assumes no liability for damage caused by careless handling or poor installation except for work completed by employees or agents of Stewart Signs. Service to a damaged or malfunctioning sign which has not been ordered or authorized by Stewart Signs' Customer Support Department is not covered under this warranty. In the event the sign is damaged during shipping it is the responsibility of the buyer to refuse delivery causing the sign to be returned to the manufacturer for repair or replacement.

The foregoing warranty is exclusive and in lieu of all other warranties whether written, oral or implied, including any warranty of merchantability or fitness for purpose.

THE STEWART SIGNS REFERRAL PROGRAM

Earn up to **\$300** when you submit information about organizations that may be interested in a Stewart sign. We'll send you **\$100** for each referral of an organization we're not currently working with that results in a sale!

TO GIVE PROPER CREDIT, PLEASE INCLUDE YOUR INFORMATION:

Your Organization's Name _____
Address _____
City _____ State _____ Zip _____
Your Name _____ Phone # () _____

ORGANIZATIONS YOU ARE REFERRING

Organization Name _____
Address _____
City _____ State _____ Zip _____
Contact Name _____ Phone # () _____

Organization Name _____
Address _____
City _____ State _____ Zip _____
Contact Name _____ Phone # () _____

Organization Name _____
Address _____
City _____ State _____ Zip _____
Contact Name _____ Phone # () _____

HOW TO SUBMIT YOUR REFERRAL:

Online: www.stewartsigns.com/referral
Toll Free Phone: 800-237-3928
Toll Free Fax: 800-485-4280
Email: advertising@stewartsigns.com with the subject line **REFERRAL**
Mail: J.M. Stewart Corporation
2201 Cantu Court #215
Sarasota, FL 34232

Email pictures of your sign to: advertising@stewartsigns.com
for placement on our website!

Share your story! Email Christine McKelvey at advertising@stewartsigns.com
if you would like a story about your sign purchase experience added to our website!



PLEASE SEND A PLANNING GUIDE TO:

Name of Organization _____

Street Address _____

City _____ State _____ Zip Code _____

Contact _____

Phone Number (_____) _____ E-mail Address _____

Name of Organization _____

Street Address _____

City _____ State _____ Zip Code _____

Contact _____

Phone Number (_____) _____ E-mail Address _____

Name of Organization _____

Street Address _____

City _____ State _____ Zip Code _____

Contact _____

Phone Number (_____) _____ E-mail Address _____

MAKE MY CHECK PAYABLE TO:

Name of Organization _____

Street Address _____

City _____ State _____ Zip Code _____

Contact _____ Phone # _____ Email Address _____

J.M. Stewart Consultant _____

** In appreciation of your patronage, should the above referrals result in a sale of a J.M. Stewart sign within the next 12 months, you or your organization will receive a \$100.00 contribution per sale.*

Publicize Your New Sign!

Most organizations acquire a sign to either identify their organization or communicate with their community. What better way to get free publicity than in a FREE newspaper article!

When an organization such as yours installs a nice new sign, it is a NEWSWORTHY event to most "hometown" newspapers. Many organizations have a "sign dedication" and invite the media to attend. You may prefer to simply notify the local media when the sign is installed so they can report their own story. Either way, properly notifying your local newspaper will increase the chance of them printing a story about your sign.

Whether you want them to print your story or have them visit your organization for a story of their own, here are some tips for preparing a PRESS RELEASE that should help you get a response from your local newspaper:

Make things easy for the Newspaper

- Provide the basic facts – who, what, when and where (exact time and date if you are planning a "sign dedication")
- Have a central contact person for more information
- Be available for follow-up questions

Make your point quickly

- Newspapers receive numerous press releases. To make yours stand out, title your press release in **BOLD** letters at the top of the page.
- What is the intended use of your new sign (i.e. identification, communication, etc...)?

Make it interesting

- Did the sign "solve" a specific need at your organization?
- Did you raise the funds for your sign in a unique way?
- Did members of the community request this sign?
- Did the community support the purchase of this sign?
- What comments have you received about your sign?

Always remember, "Less is more". Your information must fit on one page.

Don't be pushy. It is up to them if they run the article or not. Factual information is usually the most helpful, but remember, they will eventually publish as much (or as little) of your information as they want.

At the very top of the release print the words "FOR IMMEDIATE RELEASE"

Some examples are shown on the next few pages.

**SAMPLE
RELEASE**

NEWS

FOR IMMEDIATE RELEASE

(Date 00, 20XX)

Smithville High School to receive a New Sign!

Principal Steve Sherman announced today that Smithville High School will be erecting a new marquee style sign this coming weekend.

Sherman states that announcements of the events at the high school are currently communicated through their public address announcements and periodic flyers. The new marquee will allow them to more effectively communicate their events to their students and the community.

The sign was paid for in part by the high school's student council. The students sold tickets to a talent show and auctioned off manual labor services such as mowing lawns, house cleaning and detailed car washing to raise money for the sign. Sherman states, "The community really supported both events. We have often heard complaints from parents and the community that they would have attended various events at the high school if they had only known when they were occurring. We know the sign will help keep everyone informed."

The sign dedication will be this Friday at 3:00pm.

For more information, please contact Mary Jones at Smithville High School at 377-6000.

**SAMPLE
RELEASE**

NEWS

FOR IMMEDIATE RELEASE
(Date 00, 20XX)

Greenwood Baptist Church to receive a New Sign!

Pastor Bill Oakley announced today that Greenwood Baptist Church will be erecting a new marquee style sign this coming weekend.

Oakley states that announcements of the events at the church are currently communicated through their weekly bulletin and announcements at services. The new marquee will allow them to more effectively communicate their activities to their members and the community.

Greenwood Baptist Church started holding services in 1992 at the home of Mrs. Edna Johnson. In 1994, they acquired the land at their current location on Cedarville Road. Pastor Oakley, who has been leading the church since last year states, "Our new marquee is just another sign that we are a growing church! The expansion to our sanctuary will be completed next spring and we want everyone to know that you are welcome at Greenwood Baptist Church."

The sign dedication will be this Sunday at 4:00pm.

For more information, please contact Ellen Blosser at Greenwood Baptist Church at 465-0882.